

Strandsarking®

Technical Manual



CodeMark 
CMNZ10005

CodeMark 
CMNZ10006

Laminex®
NEW ZEALAND

Edition 6.0 05.24

Strandsarking®

Technical Manual

Edition 6 - May 2024

Contents

	Page	
Section 1	Strandsarking® low sloped membrane roofs	01
Section 2	Strandsarking® pitched roofs	13
Section 3	Health and safety	24
Section 4	Product warranty	27

strandsarking®

CodeMark»»
CMNZ10005

CodeMark»»
CMNZ10006



Laminex®
NEW ZEALAND

**Section 1:
Strandsarking®
Low Sloped
Membrane Roofs**

Section 1:

Strandsarking® low sloped membrane roofs

Edition 6 - May 2024

		Page
Section 1	Scope and interpretation	03
1.1	Compliance	03
1.2	Scope	03
1.3	Interpretation	03
1.3.1	NZ 3604 Commentary	03
1.4	Definitions	03
1.5	Make sure your information is up to date	03
Section 2	General product description	04
2.1	Strandsarking® material	04
2.2	Identification	04
2.3	Uses	04
Section 3	Material properties	05
3.1	Description	05
3.2	Panel dimensions	05
3.3	Panel tolerances	05
3.4	Physical properties	05
3.5	Formaldehyde	05
Section 4	Durability	06
4.1	Producer statement	06
4.2	Durability conditions	06
4.2.1	Handling and storage	06
4.2.2	Weathering	06
4.2.3	Prohibited uses	06
Section 5	Design criteria	07
5.1	Allowable spans low sloped roofs	07
5.2	Limitations	07
5.3	Specific Engineer Design (SED) - structural diaphragms	08
5.4	Masterspec	08
Section 6	Installation	09
6.1	General	09
6.2	Ventillation	11
6.3	Fasteners	11

1 Scope and interpretation

1.1 Compliance

Strandsarking® - Low Slope Membrane Roofs has a CodeMark Product Certificate CMNZ10006.

Strandsarking® also has a BRANZ Appraisal, No. 946 (2022) for Low Slope Membrane Roofs.

The CodeMark Certificate and BRANZ Appraisal No. 946 cover the use of Strandsarking® Low Slope Roofs within the scope of the New Zealand Building Code.



The valid appraisals and Codemark certificates can be viewed on the BRANZ website www.branz.co.nz

Strandsarking® for Low Slope Membrane Roofs, if designed, used, installed and maintained in accordance with the statements and conditions of this Appraisal, will meet the following provisions of the New Zealand Building Code:

Clause B1 STRUCTURE: Performance B1.3.1. B1.3.2 and B1.3.4. Strandsarking® meets the requirements for loads arising from self-weight, gravity loads, temperature, snow, wind and creep [i.e. B1. 3.3 (a), (b), (c), (g), (h) and (q)]. See Paragraphs 8.1 – 8.3.

Clause B2 DURABILITY: Performance B2. 3.1 (b), 15 years and B2.3.2. Strandsarking® meets these requirements. See Paragraph 9.1.

Clause E2 EXTERNAL MOISTURE: Performance E2.3.2. When used as part of the roofing system, Strandsarking® will contribute to meeting this requirement. See Paragraphs 13.1 and 13.2.

Clause F2 HARDOUS BUILDING MATERIALS: Performance F2.3.1. Strandsarking® meets this requirement and will not present a health hazard to people. See Paragraphs 12.1 and 12.2.

1.2 Scope

The Strandsarking® information in this manual has been specifically designed in accordance with NZS 3604 and AS/NZS 1170 to comply with the appropriate design loadings for domestic and commercial buildings.

Strandsarking® panels are suitable for timber framed buildings within the scope of NZ 3604, clause 1.1.2 and those uses specifically designed within this manual.

1.3 Interpretation

Interpretation shall be as detail in NZ 3604, clause 1.2.

1.3.1 NZS 3604 commentary

Interpretation shall be detailed in NZ 3604, clause 1.2. In particular, the words "shall" or "must" identifies a mandatory requirement for compliance with NZS 3604. The word "should" refers to practices which are advised or recommended. Clauses prefixed by "C" and printed in italic type (such as these) are intended as comments on the corresponding mandatory clauses.

1.4 Definitions

Definitions are those given in NZS 3604, clause 1.3.

1.5 Make sure your information is up to date

When specifying or installing Laminex New Zealand® product, ensure you have the current technical manual. If you are not sure you do, or you need more information, visit laminex.co.nz or call Laminex New Zealand® on 0800 303 606.

2 General product description

2.1 Strandsarking® material

High density wood-based panels are manufactured for Laminex New Zealand®, primarily for use as a roof sarking under the trademark Strandsarking®.

Panels are produced by pressing strands of wood together under heat and pressure.

The process uses a highly durable formaldehyde free resin, wax and non-solvent based organic preservative chemicals. This provides improved moisture resistance and durability.

2.2 Identification

Strandsarking® is identified by means of the words STRANDSARKING 165 64 H3.1 and the NZ Timber Preservation Council's WOODmark® symbol printed with an ink mark on the panel.

2.3 Uses

- o Is suitable to be used in residential, commercial and industrial roofing applications with a minimum roof pitch of:
 - o Membrane roofs - 2 degrees.
 - o Internal boxed gutters (within roof area), installed with a sheet membrane (refer limitations for liquid applied membranes).
 - o Profiled metal roofs.
 - Trough profile (standing seam) 3 degrees.
 - Corrugate 8 degrees.
 - o Trapezoidal - 4 degrees where crest height is less than 27mm or; 3 degrees where crest height is more than 27mm.
- o Can be fastened to timber trusses, rafters or roof framing where the support in one direction does not exceed:
 - o Membrane roofs - 600mm.
 - o Profiled metal roofs - 600mm.
(refer to allowable spans table).
- o Can be used with roofing materials weighing up to 150 kg/m².
- o Can be used in wind zones up to and including Extra High as specified in NZS 3604.
- o Approved substrate for: Ardex and Viking membranes.

3 Material properties

3.1 Description

Strandsarking® is nominally 16.3mm thick and has a textured surface to provide a more slip resistant surface than is available with smooth sanded panel products.

Strandsarking® has been manufactured using sustainable plantation grown Radiata Pine, a highly durable formaldehyde free resin, wax to improve moisture resistance and non-solvent based organic preservative chemicals.

Strandsarking® is an engineered wood panel product specifically designed for use as a sarking under membrane roofs, profiled metal roofing, and roofing materials that require continuous support.

3.2 Panel dimensions

Table 1 Sizes and weights

Strandsarking® is available in the following panel size.

Sheet size (mm)	Nominal mass per panel (kg)	Nominal mass per m ² (kg)
3600 x 800	32	11

3.3 Panel tolerances

Table 2 Tolerances on nominal dimensions

Application	Test method AS/NZS 4266.1:2017	Nominal mass per m ² (kg)		
		≤12	>12 to 22	>22
Non-sanded board	Section 4	±1.5	±1.5	±1.5
Sanded board		±0.2	±0.3	±0.3
Decorative board		±0.4	±0.6	±0.6

Note: For specialist products, the tolerance on thickness should be agreed between the manufacturer and the purchaser.

Table 3 Requirements at dispatch

Property		Test method AS/NZS 4266.1:2017	Requirement
Tolerances on nominal dimensions	Thickness	Section 4	See Table 2
	Length and width		±2 mm/m max. : ±5 mm max.
squareness tolerance		Section 4	≤2 mm/m

3.4 Physical properties

Table 4

Property	Units	AS/NZS 4266.1:2017 min / max	Strandsarking® Reported values
Bending Strength (MoR)	MPa	>19.0	32.9 MPa
Modulus of Elasticity (MOE)	MPa	>2750	4294 MPa
Internal Bond	MPa	>0.55	0.793 MPa
Thickness Swell	%	<8.0%	6.80%

Reported values tested in accordance with AS/NZS 4266.1:2017.

The properties listed in Table 4 have been determined by relevant test methods in AS/NZS 4266.1:2017, and are intended for quality assurance. They should not be used for structural design.

3.5 Formaldehyde

Meets the Super E Zero (SE0) for formaldehyde emissions when tested in accordance with AS/NZS 4266.1:2017. Meets the requirements of hazard class H3.1.

4 Durability

4.1 Producer statement

When Strandsarking® is handled, installed and maintained in accordance with this literature it will meet the provisions of Clause B2 Durability (B2.3.1(b) and as such is expected to have a serviceable life of at least 15 years.

The specifications, details and methods described herein shall be strictly observed to avoid building code non-compliance.

Laminex New Zealand® will not be liable to any person if the conditions as to storage, handling, installation and maintenance of Strandsarking® panels as outlined within this document are not complied with.

Strandsarking® panels have been treated to resist attack by insects such as borer.

4.2 Durability conditions

The following conditions shall be met; otherwise the durability of Strandsarking® will be compromised.

4.2.1 Handling and storage

- o Always stack Strandsarking® horizontally, supported by bearers at maximum 1200mm centres and laid on a flat, level and dry surface.
- o Avoid damage to Strandsarking® faces and edges.
- o For prolonged storage on site, protect the Strandsarking® panels with breathable tarpaulins or covers.
- o To prevent moisture build up under covers, ensure that there is an air gap between any covering and the Strandsarking® to allow air circulation around the pack.

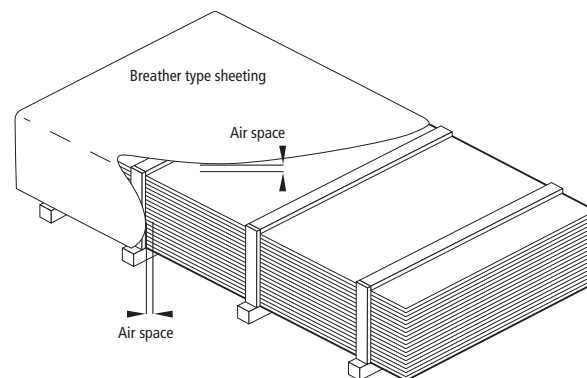

4.2.2 Weathering

- o Strandsarking® has a high degree of durability. It is not desirable to leave Strandsarking® exposed to the weather for longer than is necessary as some discoloration and checking of the surface will appear. Notwithstanding this, the maximum period of exposure to the weather of Strandsarking® should not exceed 8 weeks.
- o It is not intended that the Strandsarking® panels be re-exposed to the elements after completion of the original construction process.

4.2.3 Prohibited uses

Once the roof covering is installed, Strandsarking® should not be allowed to reach a moisture content of more than 18% for prolonged periods of time. This can occur in situations where condensation forms on the Strandsarking® and/or where leaks occur in the roof covering and/or where rain-soaked roof covering causes moisture to be driven into the Strandsarking® by the effect of the sun. Strandsarking® has been treated to the hazard class H3.1 to provide resistance from fungal decay; however this should not substitute for proper installation, maintenance or adequate ventilation of the roof space.

5 Design criteria

The design has been carried out using loads derived from NZS 3604 with the use of design combination factors as specified in AS/NZS 1170 and deflection limits as suggested in AS/NZS 1170.

The panel and fixing designs have been carried out to NZS 3603 the New Zealand Timber Structures Standard.

When designing at low pitch (at or below 5°) consideration will need to be given to the possibility of ponding due to plant installations on the roof surface at a later date and/or possible long term sag. If the life of the roofing material being used could be affected if ponding does occur, consideration must be given to increasing the pitch, or increasing the support structure (reduce main supports to 400mm centres).

The design has been carried out on the basis that the maximum temperature and humidity in the roof space is 66°C and 80%RH sustained for up to 24 hours. Further testing of the panel will be required should these values be exceeded.

5.1 Allowable spans low sloped roofs

Strandsarking® framing supports (rafters) have a maximum allowable span of 600mm centres. All sheet joins shall be fully supported with nogs (800mm centres).

The specified span between centres is the horizontal measurement between centres of the roof framing members supporting the Strandsarking® panels.

5.2 Limitations

Strandsarking® should not be used:

- o On surfaces less than:
 - o Membrane Roofs - less than 2 degrees, decks and trafficable areas.
 - o Internal boxed gutters installed with a liquid applied membranes.
 - o Profiled metal roofs - Trough profile less than 3 degrees.
 - o Corrugated profile - 8 degrees.
 - o Trapezoidal - 4 degrees where crest height is less than 27mm or; 3 degrees where crest height is more than 27mm.
- o Where the permanent load of the roofing products supported on the panel exceeds the loads specified in the allowable imposed loads section. Refer Wind zone & fixing centre table.
- o Allowable Imposed Loads: Strandsarking® panels are capable of carrying imposed cladding loads of up to 150kg/m² when spans in one direction do not exceed 600mm centres and the supporting framing has been designed to take these loads.
- o As the substrate for mechanically fastened membranes, and liquid applied membranes that have not been appraised by BRANZ to determine that they are fit for purpose.
- o In the following situations, unless specific design has been used:
 - o Where the eaves height is more than 10 metres above ground level (3 storeys).
 - o At elevations greater than 500 metres above sea level.
 - o As a diaphragm (refer to specific engineer design).
 - o On buildings outside the scope of NZBC Acceptable Solution E2/AS1 paragraph 1.1.
 - o In locations where the wind category exceeds Extra High as specified in NZS 3604.

5.3 Specific Engineer Design (SED) - structural diaphragms

If you wish to use Strandsarking® in Specific Engineer Design (SED) diaphragm applications, please contact the Laminex technical team at technical.services@laminex.co.nz

5.4 Masterspec

Find us on Masterspec: 4338LS Laminex New Zealand® Strandsarking® Roofing Substrate.

6 Installation

6.1 General

- o Check that roof trusses or framing provide a level surface for fastening the Strandsarking® onto. Trusses or rafters should be shimmed as necessary in order to provide a level surface. If the top chords of trusses or rafters are warped or bowed, install blocking to straighten.
- o Ensure that adequate roof space ventilation is provided. Refer section 6.2 Ventilation.
- o The Strandsarking® panels can be laid with the long edge perpendicular to the trusses/rafters or framing support in a staggered pattern. The ends of each sheet will be supported by truss/rafter or framing (refer to Figure 1 and Figure 2).

Figure 1 Perpendicular

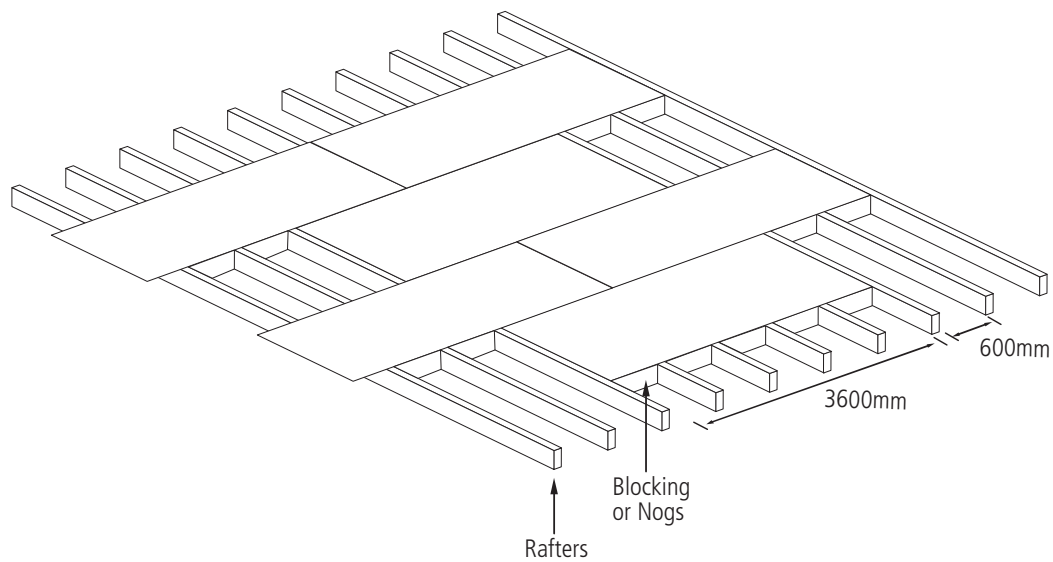
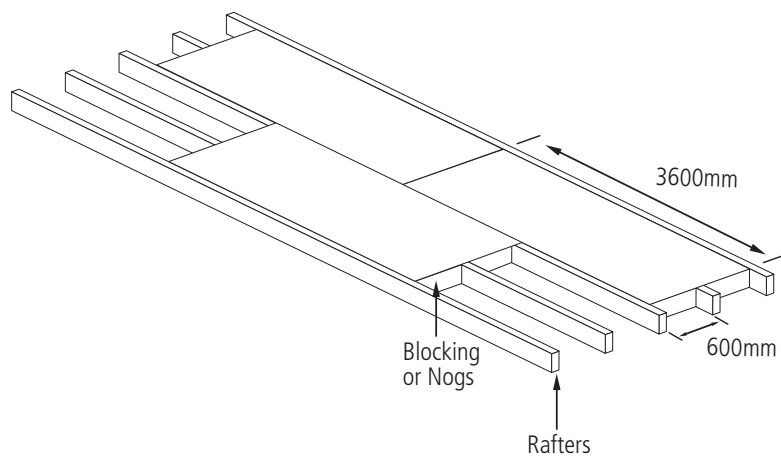
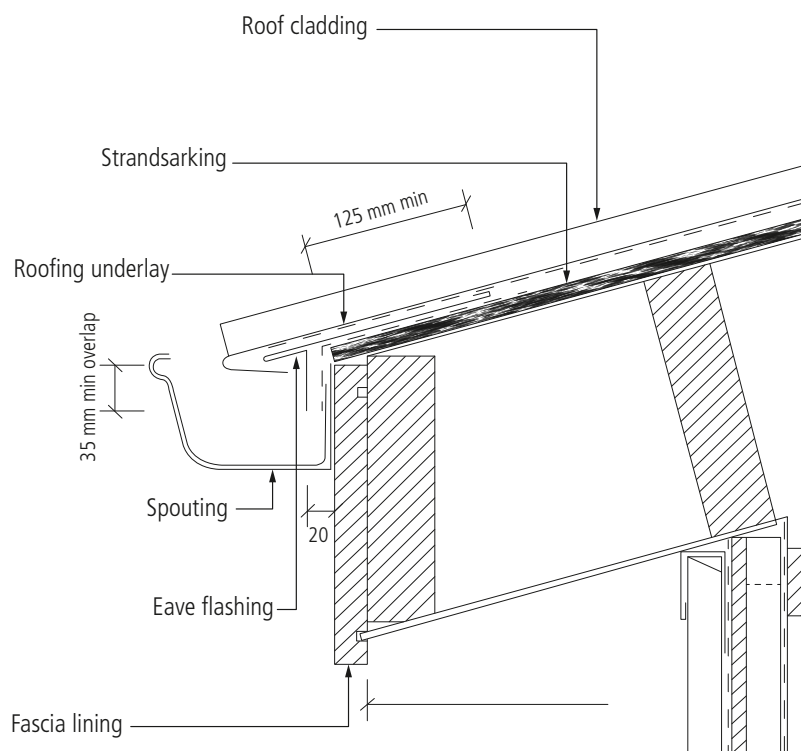

Figure 2 Parallel



- The Strandsarking® panels shall be fastened to the trusses or framing in accordance with the Wind Zone Table under section 6.3 and Figure 4.
- Strandsarking® panels can be tightly butted and fastened hard up to each other. However, roofing suppliers have held different views on the requirements for timber substrates. The fixing instruction in this document should be used as a guide or starting point only and designers must detail joints that allow for expansion in accordance with practices recommended by the chosen membrane or profiled metal roofing supplier's requirements.
- Allow a 5mm clearance between the Strandsarking® panel and other elements protruding through the roof such as vent pipes etc. Greater clearances than this may be required around flues and chimneys, see below.
- Strandsarking® must be separated from flues and/or chimneys. Part 7 of NZBC Acceptable Solution C/AS1-C/AS6 and NZBC Verification Method C/VM1 provide methods of separation and protection of combustible materials from heat sources.
- Edge of panels at gutters or eaves should be protected by drip edges, flashings, fascia trims or similar. This aids in preventing moisture ingress into the Strandsarking® in these areas. Where the design of the Strandsarking® results in the underside of the Strandsarking® being exposed to possible moisture ingress (where the panel may protrude beyond the fascia line etc.) the underside of the panel must be sealed with an appropriate exterior coating.

Figure 3



- Strandsarking® panels must be blocked as close as practical along all free edges.
- Strandsarking® panels should be installed such that there is a minimum 25mm air gap between the underside of the panel and any roof insulation material. This gap must be maintained in all situations for the life of the Strandsarking®.
- Cover the Strandsarking® with a BRANZ approved roof underlayment as soon as practical to minimise the Strandsarking® being exposed to the weather unnecessarily.

6.2 Ventilation

A well-ventilated roof space is critical to the overall performance of a roof. Good ventilation fulfils two main functions:

- It reduces moisture build up within the roof space by allowing moisture laden air to be vented to the outside.
- It reduces the temperature of the ceiling cavity.

It can also reduce the surface temperature of the roofing material by allowing a flow of air on the underside of the Strandsarking®. A general rule of thumb is that ventilation openings of at least 1/300th of the ceiling plan area is desirable, with the ventilation points being adequately distributed to ensure cross flow ventilation. The preference is for venting to be placed at the eaves and ridges. Designers should confer with roofing material suppliers and or HVAC engineers to ascertain the specific venting details and requirements for the particular roof system. Extra care must be taken when forming skillion roofs to ensure that cross flow ventilation is maintained at all times and to all areas of the ceiling cavity.

Consideration must be given to the effect of insulation in the ceiling cavity when calculating ventilation requirements.

Where the Strandsarking® has been exposed for a period of time care must be taken to ensure the moisture content of the panels is at or below 20%. Where the performance of the membrane can be affected by a build-up of moisture in the substrate, consideration must be given to providing a drainage plane immediately below the membrane. This is usually in the form of a proprietary layer that is compatible with the membrane that is installed over the top of the Strandsarking®.

Where rigid roofing materials such as standing seam roofs etc. are laid over Strandsarking®, it is recommended that a drainage plane layer is positioned over the Strandsarking® prior to the roofing material being installed.

6.3 Fasteners

Strandsarking® panels forming roofs from 2° and up to 10° are to be fixed to timber roof framing or trusses with:

- 50mm x 10 gauge (4.8mm) stainless steel screws The maximum panel fixing centres required for non-specific design wind-load areas (as per NZS 3604) are as follows: (Refer to Figure 4).

Figure 4

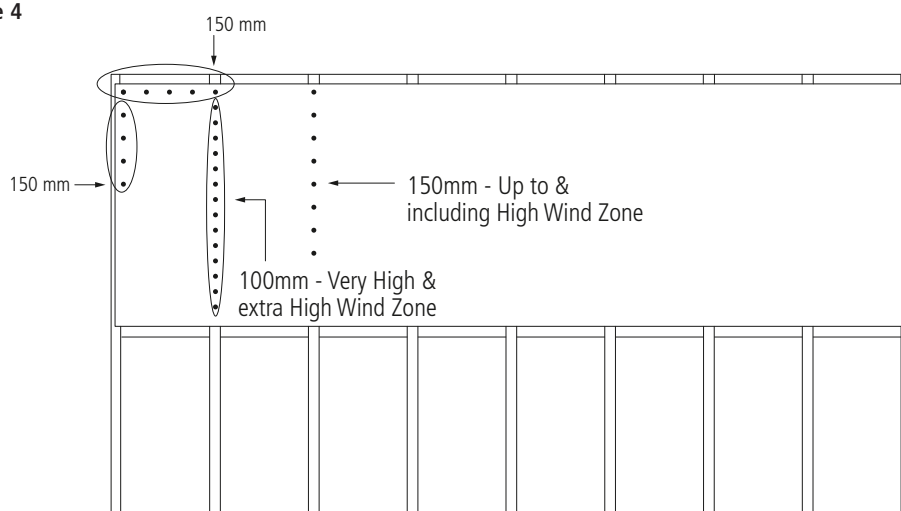

Table 7

Wind zone as per NZS 3604	Fixing centres (mm)	
	Panel ends and edges (where possible)	Intermediate supports
Up to and including MEDIUM	150	150
HIGH	150	150
VERY HIGH	150	100
EXTRA HIGH	150	100

Allowable imposed loads:

Strandsarking® panels are capable of carrying imposed cladding loads of up to 150kg/m² when spans in one direction do not exceed 600mm centres and the supporting framing has been designed to take these loads.

Section 2: Strandsarking® Pitched Roofs

Section 2: Strandsarking® pitched roofs

Edition 6 - May 2024

		Page
Section 1	Scope and interpretation	15
1.1	Compliance	15
1.2	Scope	15
1.3	Interpretation	15
1.3.1	NZ 3604 Commentary	15
1.4	Definitions	15
1.5	Make sure your information is up to date	15
Section 2	General product description	16
2.1	Strandsarking® material	16
2.2	Identification	16
2.3	Uses	16
Section 3	Material properties	17
3.1	Description	17
3.2	Panel dimensions	17
3.3	Panel tolerances	17
3.4	Physical properties	17
3.5	Formaldehyde	17
Section 4	Durability	18
4.1	Producer statement	18
4.2	Durability conditions	18
4.2.1	Handling and storage	18
4.2.2	Weathering	18
4.2.3	Prohibited uses	18
Section 5	Design criteria	19
5.1	Allowable spans	19
5.2	Limitations	19
5.3	Specific Engineer Design (SED) - structural diaphragms	19
5.4	Masterspec	19
Section 6	Installation	20
6.1	General	20
6.2	Ventillation	23
6.3	Fasteners	23

1 Scope and interpretation

1.1 Compliance

Strandsarking® Pitched Roofs has a CodeMark Product Certificate CMNZ10005.

Strandsarking® Pitched Roofs also has a BRANZ Appraisal, No.891 (2022). The CodeMark Product certificate and BRANZ Appraisal No. 891 covers the Strandsarking® pitched roofs use within the scope of the New Zealand Building Code.



The valid appraisals and Codemark certificates can be viewed on the BRANZ website www.branz.co.nz

Strandsarking® for pitched roofs, if designed, used, installed and maintained in accordance with the statements and conditions of this Appraisal, will meet the following provisions of the New Zealand Building Code:

Clause B1 STRUCTURE: Performance B1.3.1. B1.3.2 and B1.3.4. Strandsarking® meets the requirements for loads arising from self-weight, gravity loads, temperature, snow, wind and creep [i.e. B1. 3.3 (a), (b), (c), (g), (h) and (q)]. See Paragraphs 8.1 – 8.3.

Clause B2 DURABILITY: Performance B2. 3.1 (b), 15 years and B2.3.2. Strandsarking® meets these requirements. See Paragraph 9.1.

Clause E2 EXTERNAL MOISTURE: Performance E2.3.2. When used as part of the roofing system, Strandsarking® will contribute to meeting this requirement. See Paragraphs 13.1 and 13.2.

Clause F2 HARDOUS BUILDING MATERIALS: Performance F2.3.1. Strandsarking® meets this requirement and will not present a health hazard to people. See Paragraphs 12.1 and 12.2.

1.2 Scope

The Strandsarking® information in this manual has been specifically designed in accordance with NZS 3604 and AS/NZS 1170 to comply with the appropriate design loadings for domestic and commercial buildings.

Strandsarking® panels are suitable for timber framed buildings within the scope of NZ 3604, clause 1.1.2 and those uses specifically designed within this manual.

1.3 Interpretation

Interpretation shall be as detail in NZ 3604, clause 1.2.

1.3.1 NZS 3604 commentary

Interpretation shall be detailed in NZ 3604, clause 1.2. In particular, the words “shall” or “must” identifies a mandatory requirement for compliance with NZS 3604. The word “should” refers to practices which are advised or recommended. Clauses prefixed by “C” and printed in italic type (such as these) are intended as comments on the corresponding mandatory clauses.

1.4 Definitions

Definitions are those given in NZS 3604, clause 1.3.

1.5 Make sure your information is up to date

When specifying or installing Laminex New Zealand® product, ensure you have the current technical manual. If you are not sure you do, or you need more information, visit laminex.co.nz or call Laminex New Zealand® on 0800 303 606.

2 General product description

2.1 Strandsarking® material

High density wood-based panels are manufactured for Laminex New Zealand®, primarily for use as a roof sarking under the trademark Strandsarking®.

Panels are produced by pressing strands of wood together under heat and pressure.

The process uses a highly durable formaldehyde free resin, wax and non-solvent based organic preservative chemicals. This provides improved moisture resistance and durability.

2.2 Identification

Strandsarking® is identified by means of the words STRANDSARKING 165 64 H3.1 and the NZ Timber Preservation Council's WOODmark® symbol printed with an ink mark on the panel.

2.3 Uses

Is suitable to be used in residential, commercial and industrial roofing applications with a minimum roof pitch of 9 degrees or greater.

Roof systems weighing up to 25kg/m² maybe considered a Light Roof when designing structures in accordance with NZS 3604.

- Can be fastened to timber roof trusses or framing.
- Can be used with roof trusses or framing at a maximum of 900mm centres.
- Can be used with roofing materials weighing up to 150 kg/m².
- Can be used in wind zones up to and including Extra High as specified in NZS 3604.

3 Material properties

3.1 Description

Strandsarking® is nominally 16.3mm thick and has a textured surface to provide a more slip resistant surface than is available with smooth sanded panel products.

Strandsarking® has been manufactured using sustainable plantation grown Radiata Pine, a highly durable formaldehyde free resin, wax to improve moisture resistance and non-solvent based organic preservative chemicals.

Strandsarking® is an engineered wood panel product specifically designed for use as a sarking under membrane roofs, profiled metal roofing, and roofing materials that require continuous support.

3.2 Panel dimensions

Table 1 Sizes and weights

Strandsarking® is available in the following panel size.

Sheet size (mm)	Nominal mass per panel (kg)	Nominal mass per m ² (kg)
3600 x 800	32	11

3.3 Panel tolerances

Table 2 Tolerances on nominal dimensions

Application	Test method AS/NZS 4266.1:2017	Nominal mass per m ² (kg)		
		≤12	>12 to 22	>22
Non-sanded board	Section 4	±1.5	±1.5	±1.5
Sanded board		±0.2	±0.3	±0.3
Decorative board		±0.4	±0.6	±0.6

Note: For specialist products, the tolerance on thickness should be agreed between the manufacturer and the purchaser.

Table 3 Requirements at dispatch

Property		Test method AS/NZS 4266.1:2017	Requirement
Tolerances on nominal dimensions	Thickness	Section 4	See Table 2
	Length and width		±2 mm/m max. : ±5 mm max.
squareness tolerance		Section 4	≤2 mm/m

3.4 Physical properties

Table 4

Property	Units	AS/NZS 4266.1:2017 min / max	Strandsarking® Reported values
Bending Strength (MoR)	MPa	>19.0	32.9 MPa
Modulus of Elasticity (MOE)	MPa	>2750	4294 MPa
Internal Bond	MPa	>0.55	0.793 MPa
Thickness Swell	%	<8.0%	6.80%

Reported values tested in accordance with AS/NZS 4266.1:2017.

The properties listed in Table 4 have been determined by relevant test methods in AS/NZS 4266.1:2017, and are intended for quality assurance. They should not be used for structural design.

3.5 Formaldehyde

Meets the Super E Zero (SE0) for formaldehyde emissions when tested in accordance with AS/NZS 4266.1:2017. Meets the requirements of hazard class H3.1.

4 Durability

4.1 Producer statement

When Strandsarking® is handled, installed and maintained in accordance with this literature it will meet the provisions of Clause B2 Durability (B2.3.1(b) and as such is expected to have a serviceable life of at least 15 years.

The specifications, details and methods described herein shall be strictly observed to avoid building code non-compliance.

Laminex New Zealand® will not be liable to any person if the conditions as to storage, handling, installation and maintenance of Strandsarking® panels as outlined within this document are not complied with.

Strandsarking® panels have been treated to resist attack by insects such as borer.

4.2 Durability conditions

The following conditions shall be met; otherwise the durability of Strandsarking® will be compromised.

4.2.1 Handling and storage

- o Always stack Strandsarking® horizontally, supported by bearers at maximum 1200mm centres and laid on a flat, level and dry surface.
- o Avoid damage to Strandsarking® faces and edges.
- o For prolonged storage on site, protect the Strandsarking® panels with tarpaulins or similar.
- o To prevent moisture, build up under covers, ensure that there is an air gap between any covering and the Strandsarking® to allow air circulation around the pack.

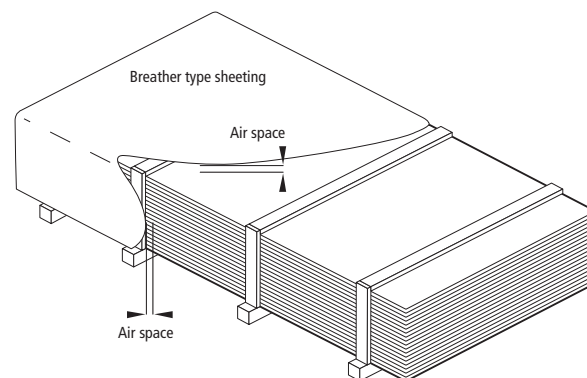

4.2.2 Weathering

- o Strandsarking® has a high degree of durability. However, it is not desirable to leave Strandsarking® exposed to the weather for longer than is necessary as some discoloration and checking of the surface will appear. Notwithstanding this, the maximum period of exposure to the weather of Strandsarking® should not exceed 8 weeks.
- o It is not intended that the Strandsarking® panels be re-exposed to the elements after completion of the original construction process.

4.2.3 Prohibited uses

Once the roof covering is installed, Strandsarking® should not be allowed to reach a moisture content of more than 20% for prolonged periods of time. This can occur in situations where condensation forms on the Strandsarking® and/or where leaks occur in the roof covering and/or where rain-soaked roof covering causes moisture to be driven into the Strandsarking® by the effect of the sun. Strandsarking® has been treated to the hazard class H3.1 to provide resistance from fungal decay; however this should not substitute for proper installation, maintenance or adequate ventilation of the roof space.

5 Design criteria

The design has been carried out using loads derived from NZS 3604 with the use of design combination factors as specified in AS/NZS 1170 and deflection limits as suggested in AS/NZS 1170. However, it is expected that Strandsarking® could deflect up to 10mm under a maintenance footfall point load, particularly where roof framing supports are at 900mm centres. If this is of concern, scaffold planks, or similar, can be used to span across roof framing members whilst working on the roof.

The panel and fixing designs have been carried out to NZS 3603 the New Zealand Timber Structures Standard.

The design has been carried out on the basis that the maximum temperature and humidity in the roof space is 66°C and 80%RH sustained for up to 24 hours. Further testing on the panel will be required should these values be exceeded.

5.1 Allowable spans

Based on the loadings as outlined in the design criteria section Strandsarking® panels are capable of spanning the centres as per the table below under the maximum imposed cladding loads as shown.

Table 5

Maximum imposed cladding weight	Span between centres
150kg/m ²	600 mm
50kg/m ²	900 mm

The specified span between centres is the horizontal measurement between centres of the roof framing members supporting the Strandsarking® panels.

5.2 Limitations

Strandsarking® should not be used:

- o On surfaces less than 2°, decks and trafficable areas.
- o Where the permanent load of the roofing products supported on the panel exceeds the loads specified in the allowable spans section (see allowable spans section).
- o As the substrate for mechanically fastened membranes and liquid applied membranes that have not been appraised by BRANZ to determine that they are fit for purpose.
- o In the following situations, unless specific design has been used:
 - o Where the eaves height is more than 10 metres above ground level.
 - o At elevations greater than 500 metres above sea level.
 - o As a diaphragm (refer to specific engineer design).
 - o On buildings outside the scope of NZS 3604.
- o In locations where the wind category exceeds Extra High as specified in NZS 3604.

5.3 Specific Engineer Design (SED) - structural diaphragms

If you wish to use Strandsarking® in Specific Engineer Design (SED) diaphragm applications, please contact the Laminex technical team at technical.services@laminex.co.nz

5.4 Masterspec

Find us on Masterspec: 4338LS Laminex New Zealand® Strandsarking® Roofing Substrate.

6 Installation

6.1 General

Check that roof trusses or framing provide a level surface for fastening the Strandsarking® onto. Trusses or rafters should be shimmed as necessary in order to provide a level surface. If the top chords of trusses or rafters are warped or bowed, install blocking to straighten.

Ensure that adequate roof space ventilation is provided (refer to Figure 1).

Figure 1

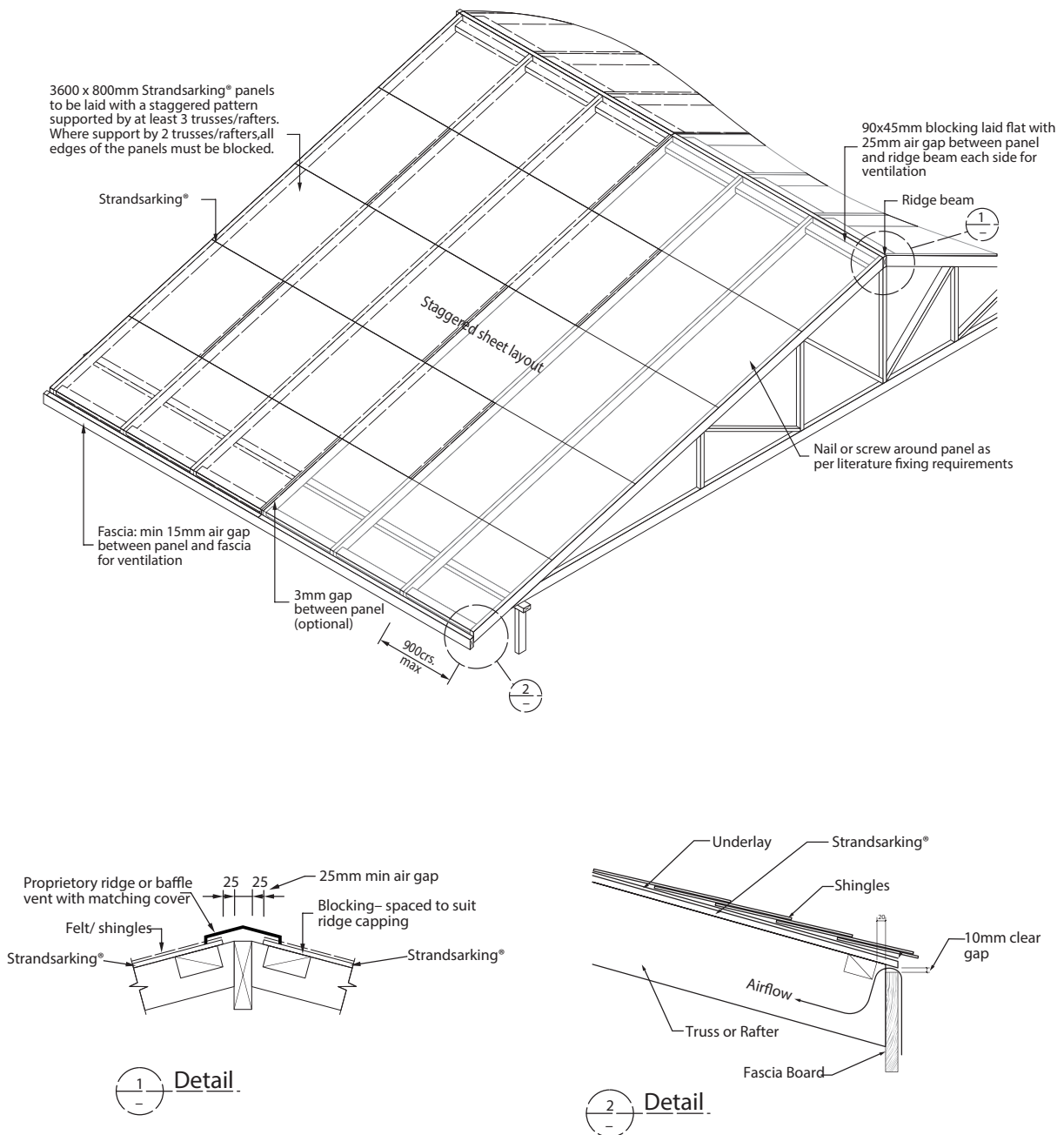

Lay the Strandsarking® panels with the long edge perpendicular to the trusses/rafters in a staggered pattern. The ends of each sheet will be supported by truss/rafter or solid blocking.

Where the Strandsarking® panels are laid over trusses/rafters pitched at less than 9°, edge support will be required. Where the pitch is at or above 9°, edge support will be required for membrane roofing but no edge support will be required for flexible shingle roofing. When installing metal roofing that requires continuous support, consider the effect of sheet edge deflection and provide support at the edge of the Strandsarking® where deflection could result in non performance of the metal roofing.

Where the Strandsarking® panels are laid over at least two spans (connected to 3 or more trusses/rafters), solid blocking (nogging) under the long edges of the panels is not required.

Where Strandsarking® is used over a single span, (supported by only two trusses/rafters) then solid blocking (nogging) **MUST** be provided under each unsupported edge.

The Strandsarking® panels shall be fastened to the trusses or framing in accordance with the fasteners section below.

Strandsarking® panels can be tightly butted and fastened hard up to each other. However, roofing suppliers have held different views on the requirements for timber substrates. The fixing instruction in this document should be used as a guide or starting point only and designers must detail joints to allow for expansion in accordance with practices recommended by the chosen membrane or profiled metal roofing supplier's requirements.

Allow a 5mm clearance between the Strandsarking® panel and other elements protruding through the roof such as vent pipes etc. Greater clearances than this may be required around flues and chimneys, refer to manufacturers details.

Strandsarking® must be separated from flues and/or chimneys. Part 7 of NZBC Acceptable Solution C/AS1-C/AS6 and NZBC Verification Method C/VM1 provide methods of separation and protection of combustible materials from heat sources.

The Strandsarking® must not overhang past the front face of the fascia (refer to Figure 1 and Detail 2). Edge of panels at gutters or eaves should be protected by drip edges, flashings, fascia trims or similar. This aids in preventing moisture ingress into the Strandsarking® in these areas. Where the design of the Strandsarking® results in the underside of the Strandsarking® being exposed to possible moisture ingress (where the panel may protrude beyond the fascia line etc.) the underside of the panel must be sealed with an appropriate exterior coating (refer to Figure 3 and Figure 4).

Figure 3

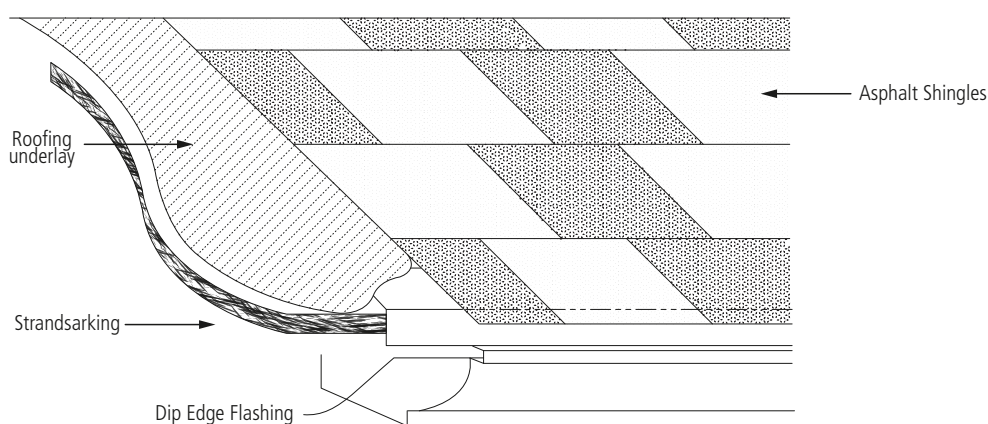

Figure 4

Eave Flashing detail – Profiled Metal Roofing

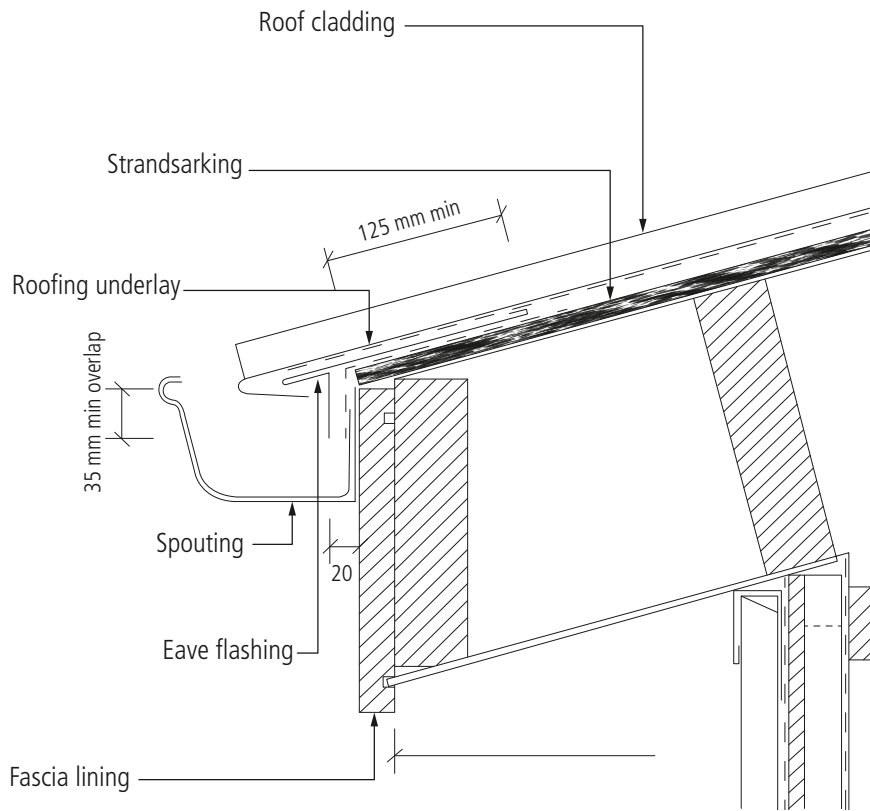
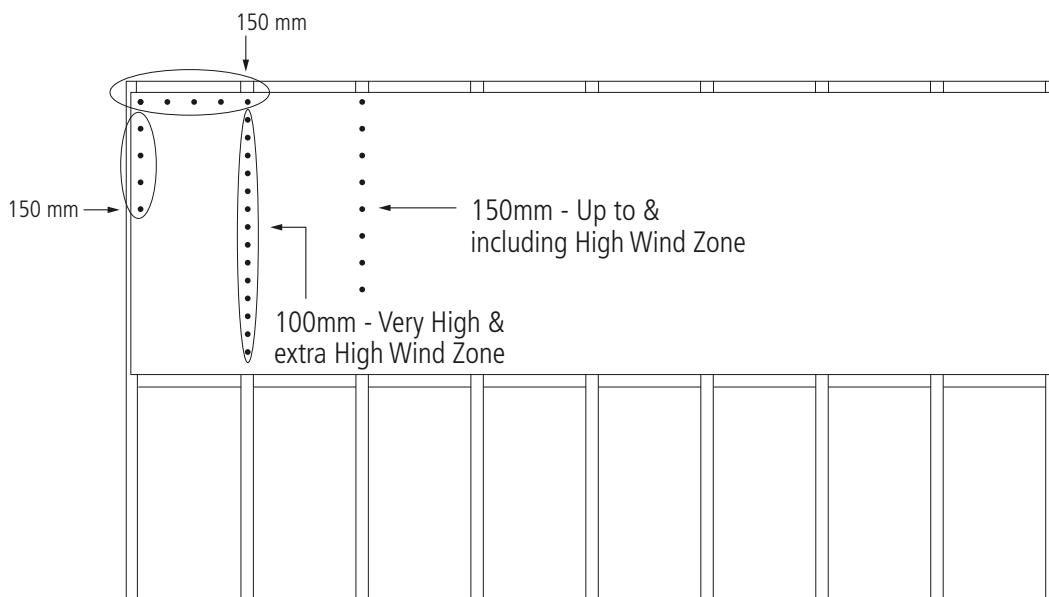

Figure 5



Where blocking is required, Strandsarking® panels must be blocked as close as practical along all free edges, with a maximum 120mm panel cantilever over the blocking if an over hang is required.

Strandsarking® panels should be installed such that there is a minimum 25mm air gap between the underside of the panel and any roof insulation material to ensure a ventilation path is provided (refer to Figure 4).

Cover the Strandsarking® with a BRANZ approved roof underlayment as soon as practical in order to minimise the Strandsarking® being exposed to the weather unnecessarily.

Exposure of the Strandsarking® to the elements during the construction period should not exceed **8 weeks**.

6.2 Ventilation

A well ventilated roof space is critical to the overall performance of a roof. Good ventilation fulfils two main functions:

- o It reduces moisture build up within the roof space by allowing moisture laden air to be vented to the outside.
- o It reduces the temperature of the roof space by allowing a flow of air on the underside of the Strandsarking®. It can also reduce the surface temperature of the roofing material. A general rule of thumb is that a ventilation area of at least 1/300th of the ceiling area is desirable, with the ventilation being adequately distributed throughout the roof area and between the eaves and ridges.

A clear uninterrupted ventilation air gap must be provided between the underside of the Strandsarking® and any insulation material. A minimum gap of 25mm must be provided, however a greater gap must be considered where skillion roofs are being formed.

Roofing material suppliers must be consulted in order to ascertain the specific venting details and requirements for their particular system. Refer to Detail 1 and Detail 2 in Figure 1 for minimum ventilation openings at ridge and eaves.

6.3 Fasteners

Strandsarking® panels are to be fixed to timber roof framing or trusses with either:

- o 65mm x 2.8mm diameter ring shank hot dipped galvanised flat head nails, or
- o 65mm x 2.8mm diameter ring shank stainless steel flat head nails, or
- o 50mm x 10 gauge (4.8mm) stainless steel screws.

Strandsarking® panels are to be fixed to timber roof framing or trusses with either (refer to Figure 5):

Table 6

Wind zone as per NZS 3604	Fixing centres (mm)	
	Panel ends and edges (where possible)	Intermediate supports
Up to and including MEDIUM	150	150
HIGH	150	150
VERY HIGH	150	100
EXTRA HIGH	150	100

Note: Fixing along panel edges must be at least 10mm from the panel edge.

Section 3:

Health and safety

		Page
Section 1	Health and safety	25
1.1	Working conditions	25
1.2	Safe working practices	25
1.3	Formaldehyde	25
1.3.1	Control	25
1.3.2	Formaldehyde facts	26
1.3.3	Risks	26
1.3.4	Detecting formaldehyde	26

1 Health and safety

1.1 Working conditions

- Health and safety precautions shall be taken when working with wood panel products.
- Occupational exposure to wood dust from any timber has been classified as hazardous. Wood dust is classed as a known carcinogenic to humans and its inhalation over many years increases the risk of nasal cancers. Similar exposure to uncontrolled wood dust can lead to allergic reactions such as dermatitis, asthma or chronic eye, nose and throat irritation in some people. Common symptoms of wood dust irritation are nasal discharge, dry or sore nose/throat, blocked, bleeding or itchy nose, sneezing, catarrh or coughing.
- Work areas shall be well ventilated and kept clean.
- Strandsarking® has been manufactured with polymeric diphenylmethane diisocyanate (pMDI) as a resin. This remains in the finished board in the form of polyurea or polyurethane. Evidence suggests that this causes no health effects in the normal population.
- The resin used to manufacture Strandsarking® is non-formaldehyde based. Despite that, low levels of formaldehyde gas naturally present in the wood may be released from the product under some conditions. Formaldehyde is classified as a known carcinogen. However, in well ventilated areas the concentration of formaldehyde is unlikely to exceed the World Health Organisation Standard of 0.1 ppm for the general environment. The product is classified as Super E Zero (SE0) when tested in accordance with AS/NZS 4266.1: 2017 Formaldehyde Emission - Desiccator Method, similar classification as solid untreated wood.
- Work areas must be well ventilated and kept clean. Sawing, sanding and routing equipment should be fitted with dust extractors such that dust levels are kept within standards outlined by Worksafe Australia, Worksafe New Zealand or the specific country of use. If not, wear a Dust Mask conforming with AS/NZS 1715 and AS/NZS 1716 and eye protection conforming with AS/NZS 1337.
- Offcuts, shavings and dust shall be disposed of in a manner that avoids the generation of dust and in accordance with the requirements of local waste authorities.
- In end use applications all product surfaces exposed to occupied space shall be sealed. In end use applications all product surfaces exposed to occupied space shall be sealed.

1.2 Safe working practices

- Never use a power saw in a poorly ventilated area.
- Always use M class extractor unit as a minimum.
- Always use an approved sharp sawblade when cutting wood panels.
- Always follow tool manufacturers' safety recommendations.
- Always wear an approved properly-fitted approved dust mask (P1 or P2).

1.3 Formaldehyde

1.3.1 Control

- When installed, emission levels can be controlled by room ventilation and covering of the surface.
- The surface shall be sealed or covered with a coating system or alternatively, with a floor covering such as foam-backed carpet, carpet with rubber underlay, sheet vinyl or ceramic tiles.
- Sealing or covering of the surface shall be carried out before the building is occupied.
- When it is anticipated that the building may be closed for long periods of time, "trickle" ventilators shall be provided.

1.3.2 Formaldehyde facts

- Formaldehyde is a clear, naturally occurring gas, which is given off by plants, animals and human beings as part of the normal life process. Formaldehyde is used in a wide range of consumer products and scientific and industrial processes.
- Formaldehyde is biodegradable, being destroyed by exposure to the atmosphere and by biological processes in soil and water, plants, animals and human beings.
- Because some people can react to low levels of formaldehyde exposure, all possible sources of emissions in homes should be checked.
- Among the factors which can lead to a build-up of formaldehyde levels in some homes are:
 - Unsealed or uncovered reconstituted wood flooring.
 - Unpainted or unsealed reconstituted wood products such as door jambs, scotias and skirting boards, doors and plywood.
 - Unpainted or unsealed furniture made out of reconstituted wood products like cupboards, chests of drawers and kitchen and laundry units.
 - Thermal backed curtaining and upholstery.
 - LPG-Fuelled heaters and cookers (unflued).
 - Cooking with hot oil.
 - Cigarette smoke.

1.3.3 Risks

- Formaldehyde is a natural gas, which will break down when exposed to the atmosphere, but in confined spaces this dissipation is slower.
- Formaldehyde is irritating to the nose and throat, eyes and skin. Some people are hypersensitive to formaldehyde and experience allergic reactions resembling asthma. They also experience runny noses and skin reactions.

1.3.4 Detecting formaldehyde

- Air-borne formaldehyde is detectable by smell at about 0.3 – 0.4 parts per million (ppm) and at this level may cause mild eye irritation for some people.
- At 0.5 ppm some people notice a mild effect in the throat. At 1.0 ppm and over, watering of the eye begins. At 10.0 ppm, intolerable irritant effects on the nose and throat are felt.

Section 4: Product warranty

Page

Section 1 Product warranty

28

1 Product warranty

Refer to Laminex New Zealand® website for full warranty terms & conditions.

VISIT US

laminex.co.nz

CALL US

0800 303 606

J011356 - 05/24

© Copyright 2004, Laminex New Zealand®. Strandsarking® is marketed and distributed by Laminex New Zealand®, a division of Fletcher Building Products Ltd. Strandsarking® logo, is a trademark of Fletcher Building Holdings and used under licence by Laminex New Zealand®, a division of Fletcher Building Products Ltd. Laminex New Zealand® are trademarks used under licence by Laminex New Zealand®, a division of Fletcher Building Products Ltd.

Laminex®
NEW ZEALAND