



 **LG Hausys**  
Authorised distributor

# HI-MACS<sup>®</sup>

Design Guide 2022

**Laminex<sup>™</sup>**  
NEW ZEALAND



Acrylic Solid Surface



# Introduction

Laminex New Zealand™ is pleased to introduce HI-MACS® Acrylic Solid Surface. Whatever your project may be, we are confident you will find it is an excellent choice for interior surfaces.

This Design Guide has been created to give basic guidelines to designers to help ensure that HI-MACS® Acrylic Solid Surface will be designed, fabricated, and installed correctly to achieve our ultimate goal - giving clients and end users the peace of mind of having one of the finest products in their homes and businesses.

Your local Laminex New Zealand™ representative is always available for any questions that you may have about HI-MACS® Acrylic Solid Surface. They are also supported by our Technical Services team, who can give detailed project advice to make sure that your final installed project meets your design intentions.

Laminex New Zealand™ has been distributing solid surfaces in New Zealand for longer than any other company. We have decades of practical experience within our team, and we are able to offer national sales support, backed by a meaningful 15 year warranty.

## **CONTACT DETAILS:**

**Laminex New Zealand™**

**T: 0800 303 606**

**W: [laminex.co.nz](http://laminex.co.nz)**

---

# Disclaimer

The information contained here is deemed reliable; however, none of the contents—including but not limited to the recommendations, pictures, techniques, and or instructions—is to be conceived as implying legal liability of fitness for a particular purpose, any other type of warranty, or being exhaustive or conclusive in its coverage and nature of information.

We recommend that designers and user's take all necessary measures and precautions in order to confirm and test the adequacy of any product being considered for a specific application. If samples of HI-MACS® Acrylic Solid Surface are required for such testing, please contact Laminex New Zealand™ or your local fabricator.

The information contained herein is strictly for purposes of reference and as such, Laminex New Zealand™ and its affiliates assume no liability for its accuracy or suitability or the use of such information for products other than HI-MACS® Acrylic Solid Surface.

# Contents

<b>Product Overview</b>	4
<b>Product Applications</b>	5
HI-MACS® Commercial	6
HI-MACS® Kitchen	7
HI-MACS® Bathroom	8
HI-MACS® Outdoor	9
<b>HI-MACS® Colour Range</b>	10
Hi-Macs® Marmo Collection	11
Product Range	12
Samples Vs. Full Sheet	12
HI-MACS® Sinks & Basins	13
<b>Design Guidelines</b>	
Colour Selection	14
Directional Patterns or Reflectivity	15
Edge Profiles	16
Benchtop Cutouts	17
Sink Drainer	17
Overhang Support	18
Thermoforming	19
HI-MACS® Ultra Alpine White	20
Thermoforming Specifications	21
Kitchen splashbacks	22
Backlighting	23
Specification Notes	24
<b>Performance Reports</b>	25
Cleaning Recommendations	25
Test Method	26
Chemical Resistance	26
<b>Frequently Asked Questions</b>	27
<b>Care &amp; Maintenance</b>	28

---

# Product Overview

HI-MACS® Acrylic Solid Surface is an acrylic material suitable for residential and commercial applications because of its beauty, durability, aesthetics, design flexibility, colour choices, and more. HI-MACS® Acrylic Solid Surface products are non-porous and are manufactured in accordance with environmental standard ISO:14001 and are NSF and GREENGUARD Certified.

It can be applied in many applications where sanitation is of utmost importance, such as kitchen benchtops, hospitals, playrooms, schools, and many more. HI-MACS® Acrylic Solid Surfaces can be fabricated and installed in almost any application with inconspicuous seams, making HI-MACS® Acrylic Solid Surface truly “Solid” in surfacing materials.

The design flexibility and usability of HI-MACS® Acrylic Solid Surface, such as integrated sinks and covered back-splashes, makes it a perfect combination of Beauty, Design, and Practicality. Every HI-MACS® Acrylic Solid Surface is covered by a fifteen-year Limited Warranty backed by nationwide technical and sales support provided by Laminex New Zealand™.

---

## FEATURES & BENEFITS

---

- Non-porous
  - Hygienic
  - Repairable
  - Thermoformable
  - Meaningful 15 Year warranty
  - Design flexibility
  - Seamless finish
  - Durable
  - Renewable
  - GREENGUARD gold and NSF accredited
  - Stain resistant
  - Mildew resistant
  - Fade resistant
-

# Product Applications

HI-MACS® Acrylic Solid Surface is an ideal hygienic material for kitchens and bathrooms due to its resistance to heat, moisture, pollutants, UV and other harmful agents. With a wide selection of colours and design applications, HI-MACS® Acrylic Solid Surfaces can transform any space into a beautiful environment. The unlimited design flexibility makes it a perfect material to use in commercial applications. Many commercial builders are using solid surfaces in hospitals, restaurants, hotels, schools, banks and other areas because of all the advantages solid surface has to offer.

---

## COMMERCIAL

---

Table tops, countertops, wall linings, bar tops, furniture, partitions, vanities, shelves, reception counters, ornaments and serving dishes

---

## RESIDENTIAL

---

Benchtops, wall linings, vanities, dining and occasional tables, laundries, shelves, bar tops and furniture.

---

## OUTDOORS

---

Outdoor furniture and outdoor facades.

---

# HI-MACS® Commercial



Photo credit ©Gensler Los Angeles

S028 ALPINE WHITE



S028 ALPINE WHITE



# HI-MACS® Kitchen



S028 ALPINE WHITE



M608 AURORA GREY



# HI-MACS® Bathroom



M605 AURORA SANREMO



S028 ALPINE WHITE

# HI-MACS® Outdoor



S028 ALPINE WHITE



S028 ALPINE WHITE



# HI-MACS® Colour Range

## SOLID



S028 Alpine White



S006 Arctic White



S034 Diamond White



S302 Opal



S304 Ruby

## ULTRA SERIES



S928U Ultra Alpine White

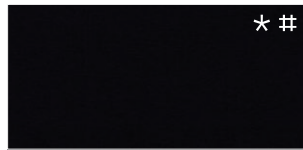

S922U Intense Ultra Black

## GRANITE

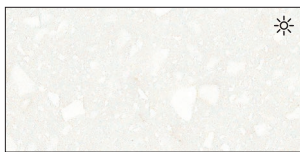

G034 Arctic Granite



G235 Candy White

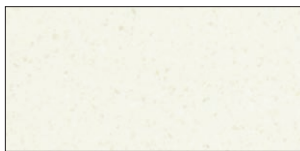

G110 Corona



G101 Crystal Beige

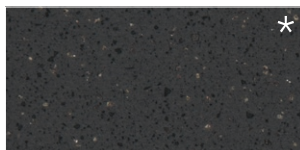

G115 Whinstone



G004 White Quartz



G555 Steel Concrete

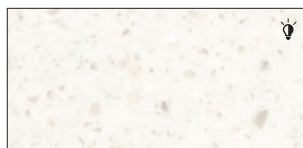

VW01 Gemini

## MARBLE



M423 Ancona



M421 Passo



M608 Aurora Grey



M606 Aurora Bianco

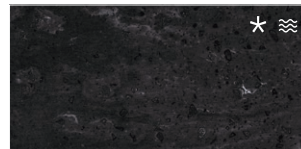

M605 Aurora Sanremo



M603 Aurora Pavia

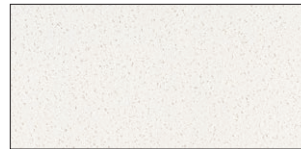

T017 Andromeda



M601 Aurora Torano

- \* Darker and more heavily pigmented colours will show dust, scratches, haziness, marks left by hard water and other ordinary wear. Extra care is needed for high wear applications such as benchtops
- ☀ Suitable for exterior use. Please check conditions about level of suitability and warranty per colour
- # Shows less scratches, dust, marks and whitening compared to the standard black and greys and other dark colours offered or in the market, as well as improved thermoforming capabilities
- ≈ As Marmo is a randomly veined product, specific fabrication guidelines need to be followed. Ask our sales representative for more information
- 💡 Lucent colours have a higher level of translucency, more evident when combined with light source
- 💡 Colours with this mark have a semi-translucent effect, evident when combined with light sources

### Finish:

There may be some slight variation in colour between the illustrated and the sample due to printing techniques, colour may vary slightly from the sample.



# HI-MACS® Marmo Collection



**M606** Aurora Bianco



**M608** Aurora Grey

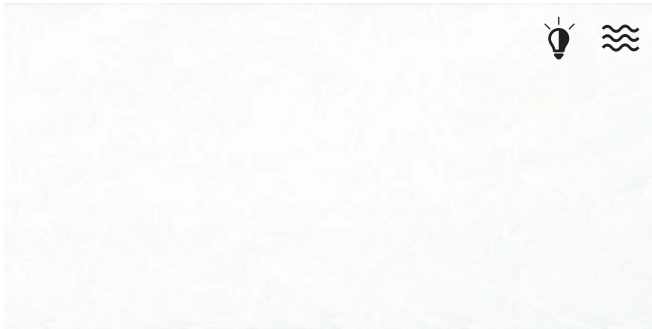

**M603** Aurora Pavia



**M605** Aurora Sanremo

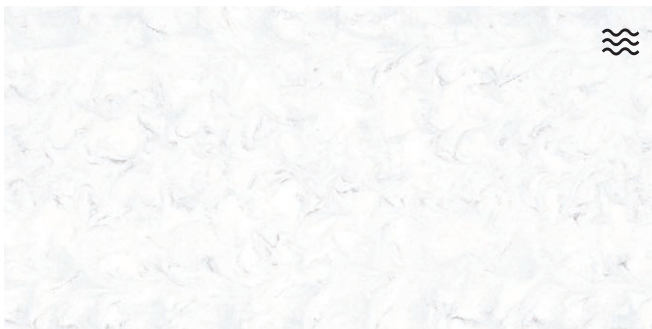

**M601** Aurora Torano



**M421** Passo



**M423** Ancona

# Product Range

SHEET SPECIFICATION							
Sheet thickness in mm	Sheet width in mm	Sheet length in mm	m <sup>2</sup> /Sheet	kg/Sheet		kg/m <sup>2</sup>	
				Solid	Granite	Solid	Granite
6*	760	2,490	1.89	19.9	19.3	10.5	10.2
12	760	3,680	2.80	58.7	57.1	20.9	20.4

\* 6mm is available in Alpine White, recommended for vertical use only.

All the benefits of Hi-Macs with sleek clean lines and can be enhanced with a matching integrated sink or sinks.

## Samples vs Full Sheet

While a sample gives a good idea of the look and feel of a full sheet it is only a small piece of the full sheet. We recommend that a customer views the full sheet prior to fabrication to ensure that it meets expectations. This only applies to the Marmo collection where there is a pattern and grain in the sheet.

HI-MACS® solid surface is supplied unfinished. Please ensure you specify your desired finish prior to fabrication. Matte and Satin finishes are more suited to high wear applications, as high gloss finishes tend to show more signs of wear.

**Ultra-Intense Black:** To achieve an extreme black look the surface needs to have a gloss finish.

There may be some slight variation in colour between the illustrated and the sample due to printing techniques, colour may vary slightly from the sample.

# HI-MACS® Sinks & Basins

## SINKS

HI-MACS® Sinks are available in Alpine White S028.

These can be seamlessly integrated into your Hi-Macs surface to eliminate any sealants.

Sinks & Basins are not supplied with overflow outlets but can be installed after consultation with the fabricator if required.

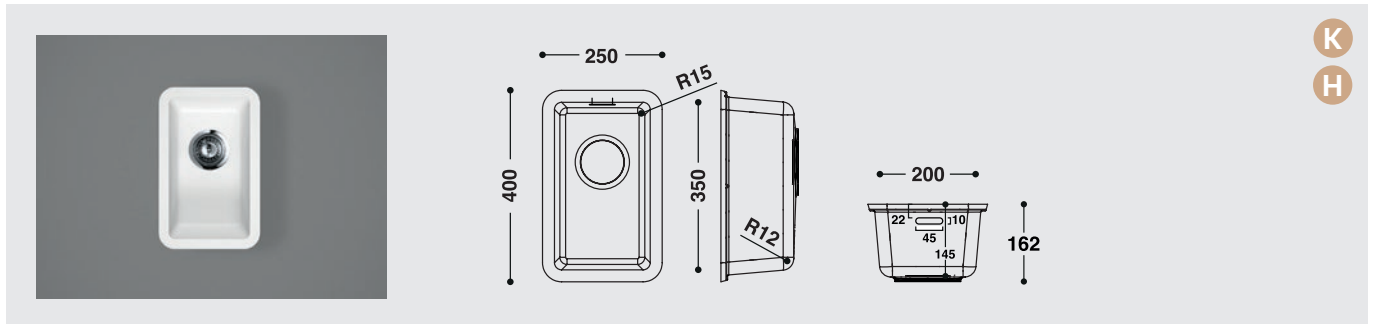

CS204

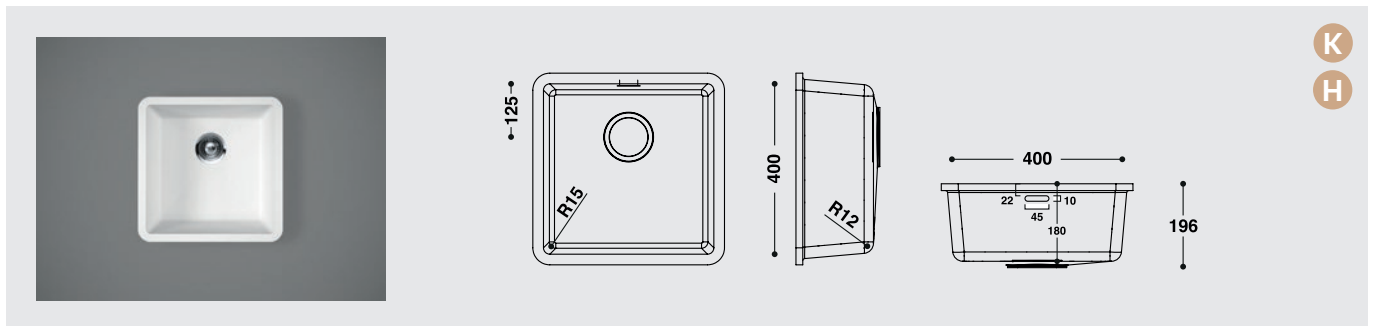

CS404

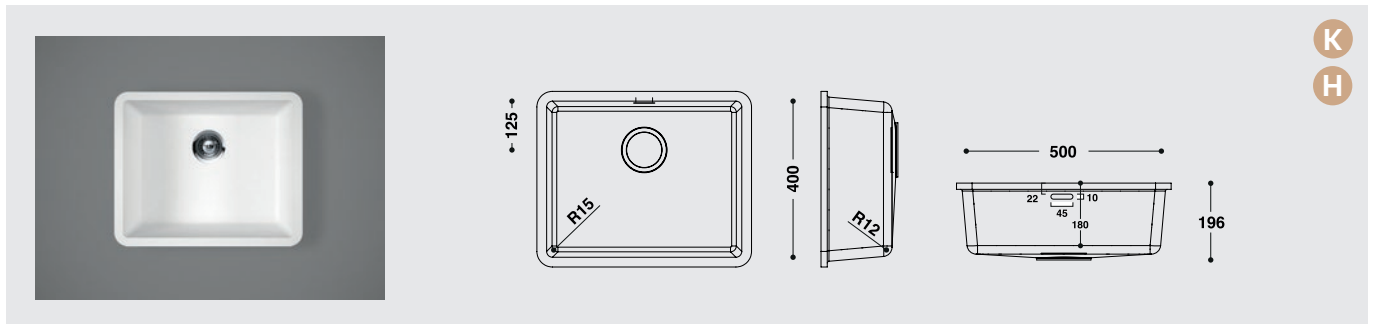

CS504

## BASIN

HI-MACS® Basins are available in Alpine White S028.

These can be seamlessly integrated into your Hi-Macs surface to eliminate any sealants.

Sinks & Basins are not supplied with overflow outlets but can be installed after consultation with the fabricator if required.

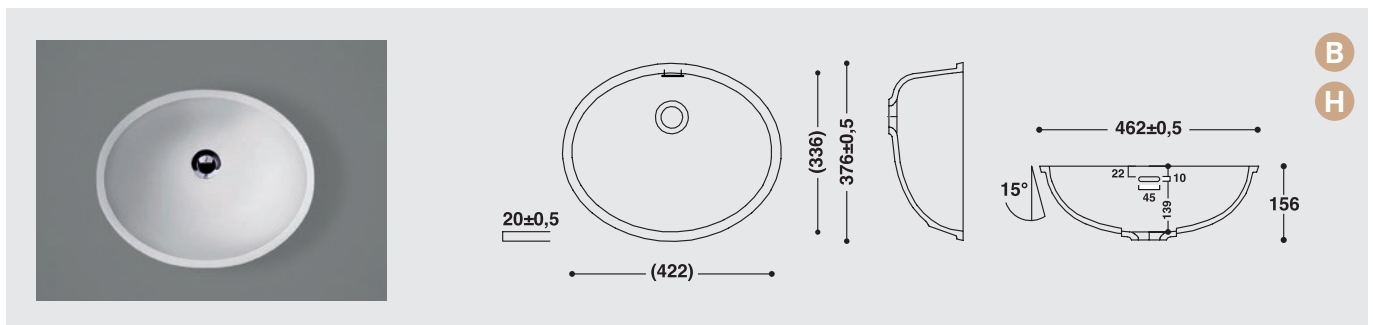

CB422

Custom made and thermoformed bowls can be manufactured by approved Hi-Macs fabricators.

For more details, please contact Laminex New Zealand™.



# Colour Selection

---

## ADVANTAGES & DISADVANTAGE OF DIFFERENT COLOURS AND FINISHES

---

To ensure customers' expectations are met it is important to understand the advantages and disadvantages of different colours and finishes.

The basic composition of all HI-MACS® Acrylic Solid Surface is the same, however, it is important to understand that certain dark or heavily pigmented colours, and special designed patterns are not recommended for certain applications.

Dark colours and high gloss finishes are not recommended in applications that are subject to heavy use, due to its increased care and maintenance requirements needed to maintain their appearance.

Since dark colours and high gloss finishes are more likely to show scratches, and other ordinary wear and tear compared to the lighter, textured colours, it is recommended that customers use caution when choosing these colours for high wear applications. Testing on a sample is suggested.

# Directional Patterns or Reflectivity

Due to the directional pattern or reflectivity in the sheet, consideration must be given to the way in which the individual benchtops are fabricated. Where the top changes direction there is the option of mitring the corner or continuing the grain in the same direction, this will often depend on the layout of the bench and discussion with the fabricator would be advised prior to manufacture.



M426 Laviano

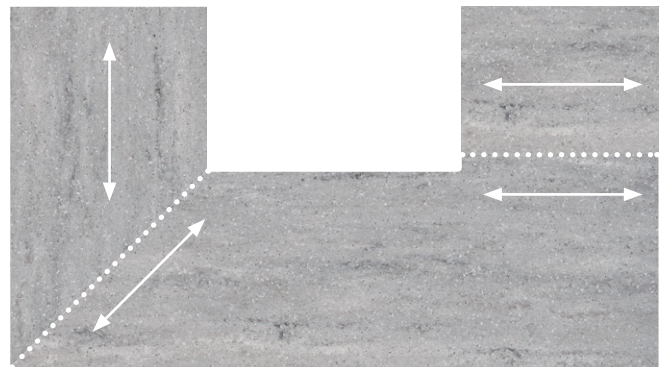

M426 Laviano

In the situation where the benchtop is larger than the sheet size (3680 x 760) and due to the variation in the grain colour and pattern, the grain change may be visible in parts of the join.

The fabricator will take all practical steps to find the most appropriate match for the join; this will not detract from the overall appearance of the benchtop as the greater part of the join will merge as one.

---

## DIRECTIONAL PATTERN & REFLECTIVITY

---

The following colours within the HI-MACS® Acrylic Solid Surface range have a directional pattern and reflectivity in the sheet.

- |                       |                      |
|-----------------------|----------------------|
| ■ M606 Aurora Bianco  | ■ M601 Aurora Torano |
| ■ M608 Aurora Grey    | ■ M421 Passo         |
| ■ M603 Aurora Pavia   | ■ M423 Ancona        |
| ■ M605 Aurora Sanremo |                      |
-

# Edge Profiles

Having the right decorative edge profile can be very important in the final design. Decorative edges are easy to achieve and can take nearly any form, your imagination being the only restriction.

The edge detail can be fabricated by either an inconspicuous join or thermoformed. The size and shape is endless.

Our authorised fabricator network are skilled at transforming ideas in to a vast spectrum of designs to enhance the final product.

Among the many different types of decorative edges, some commonly used edges are:

---

## EDGE PROFILE EXAMPLES

---

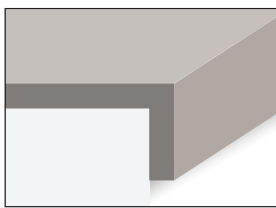

Square

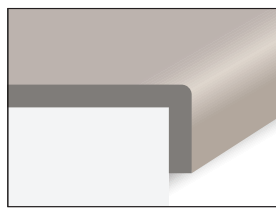

Single pencil round

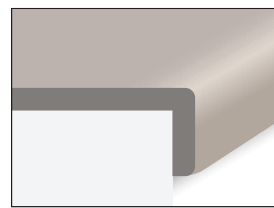

Double pencil round



Bull-nose

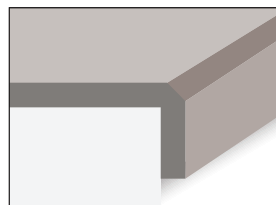

Single bevel

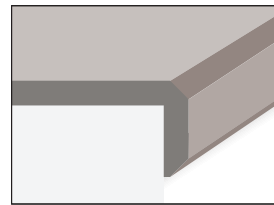

Double bevel

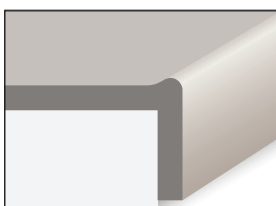

Waterfall edge

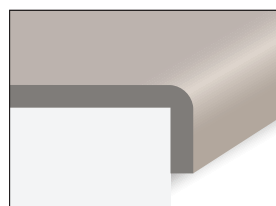

Single round

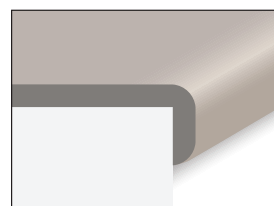

Double round

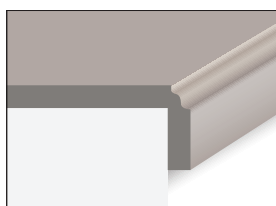

Cyma reversed

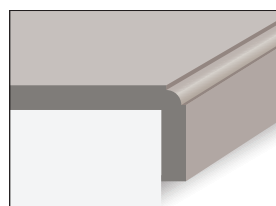

Single ovolo

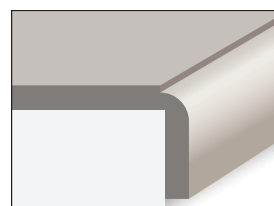

Single imperial



# Benchtop Cutouts

When designing the inclusion of sinks, cooktops and any other item that requires cutouts in the benchtop, a minimum radius of 9.5mm for all internal corners must be included. Corners cannot be square cut.

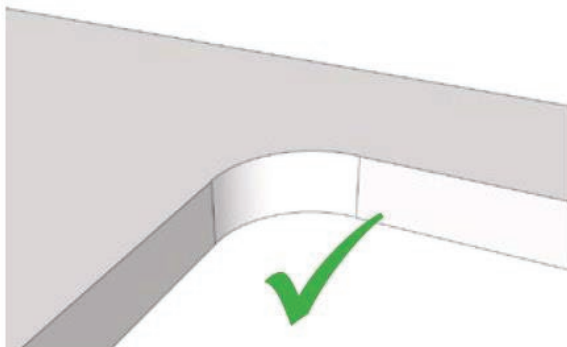

Figure 1

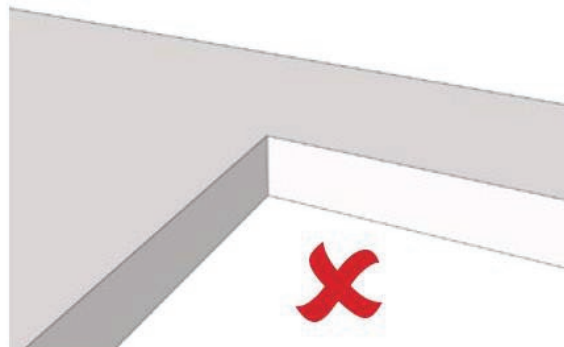
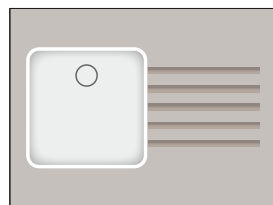

Figure 2

# Sink Drainers

Sink draining grooves can be easily included in a HI-MACS® Acrylic Solid Surface benchtop. Where grooves are deeper than 3mm an extra panel would need to be attached under the drainer.

## DRAINER GROOVE EXAMPLES



Straight grooves

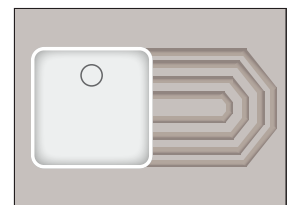

Facetted

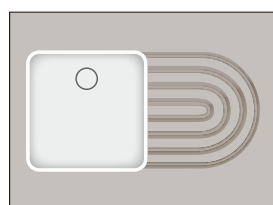

Curved

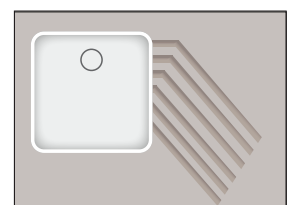

Oblique

# Overhang Support

Depending on the project, you might be required to provide an overhang support for a benchtop or countertop. The following are some guidelines to follow when working with overhangs.

OVERHANG	12mm
0 to 200mm	No additional support required
200 to 300mm	Plywood or MDF substrate or brackets or suitable square metal tube
300 to 450mm	Plywood or MDF substrate and brackets or suitable square metal tube
450mm +	Legs or Column

## BRACKET SUPPORT

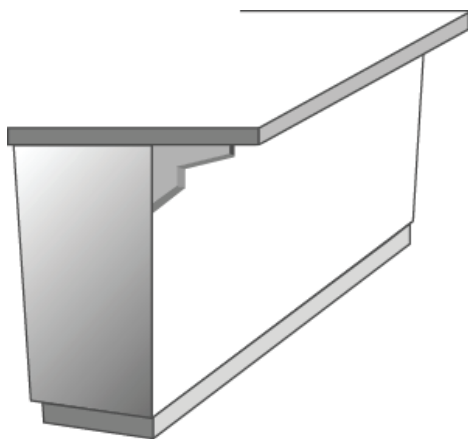

## UNSUPPORTED

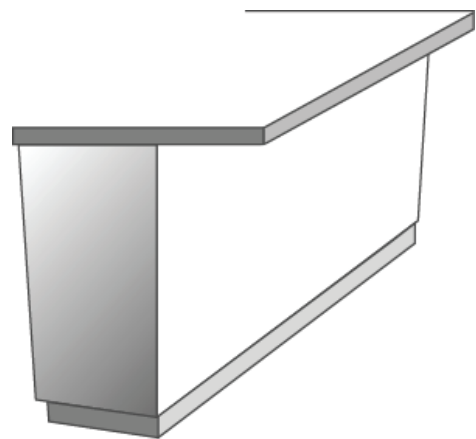

# Thermoforming

Thermoforming is the process of heating and moulding HI-MACS® Acrylic Solid Surface to a desired 2D or 3D shape.

---

## THE BASIC PROCESS INVOLVES:

---

1. The HI-MACS® Acrylic Solid Surface material is heated in an oven to a specific temperature to allow it to become formable.
2. The material is taken from the oven and placed into a mould to form it into the desired shape. In some instances, a male and female mould is required, or a vacuum, to form the material.
3. The material is allowed to cool in the mould. Once it has cooled, it will permanently retain the new shape and its tensile strength.





# HI-MACS® Ultra Alpine White

---

## THE HERO IN OUR RANGE - ALPINE WHITE

---

HI-MACS® Ultra-Thermoforming allows for even more extreme curves. The minimum inner radius of 6mm (usually 50mm) offers a completely new design dimension. The product has 30% greater flexibility, which allows designers to create much sharper curves. Even the smaller radii can be created without affecting the material properties.

The new ultra-thermoforming capabilities in popular Alpine White is available in a thickness of 12mm and can be used indoors and outdoors.



# Thermoforming

The basic composition of all HI-MACS® Acrylic Solid Surface is the same, however, the degree of thermoforming varies for each colour. Generally speaking, colours that have larger

chips cannot be thermoformed to as tight a radius as solid colours. The table below specifies the minimum internal radius that each colour can be thermoformed to.

12mm COLOURS				
Product #	Colour	Colour Code	Sub-Category	Minimum internal thermoforming radius
<b>3680 x 760 x 12mm</b>				
991498	Alpine White	S028	Solids	50mm
991499	Arctic White	S006	Solids	50mm
991500	Diamond White	S034	Solids	50mm
991506	Opal	S302	Lucent	50mm
991507	Ruby	S304	Lucent	50mm
991508	Arctic Granite	G034	Granite	60mm
991525	Candy White	G235	Granite	60mm
991528	Corona	G110	Granite	60mm
991529	Crystal Beige	G101	Granite	60mm
991538	Whinstone	G115	Granite	60mm
991539	White Quartz	G004	Granite	60mm
991522	Steel Concrete	G555	Concrete	60mm
991547	Gemini	VW01	Volcanics	200mm
991550	Andromeda	T017	Aster (Galaxy)	200mm
991544	Intense Ultra Black	S922U	Intense Series	6mm
991498	Ultra Alpine White	S928U	Intense Series	6mm
991556	Ancona	M423	Marmo	200mm
991551	Aurora Bianco	M606	Marmo	100mm
991622	Aurora Grey	M608	Marmo	100mm
991553	Aurora Pavia	M603	Marmo	100mm
991555	Aurora Sanremo	M605	Marmo	100mm
991554	Aurora Torano	M601	Marmo	100mm
991621	Laviano	M426	Marmo	200mm
991620	Passo	M421	Marmo	200mm
6mm COLOURS				
Product #	Colour	Colour Code	Sub-Category	Minimum internal thermoforming radius
<b>3680 x 760 x 6mm</b>				
991496	Alpine White	S028	Solids	20mm

**Note:** The above chart is an estimated number. Take necessary precautions and where possible, test when thermoforming Laminex® Solid Surface products.

# Kitchen Splashbacks

HI-MACS® Acrylic Solid Surface can be used as a splashback offering low maintenance, easy to clean surface with a seamless look and continuity of benchtop colour.

## SPLASHBACKS

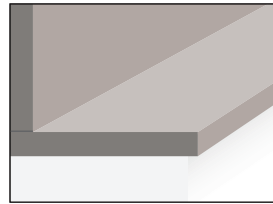

Square upstand

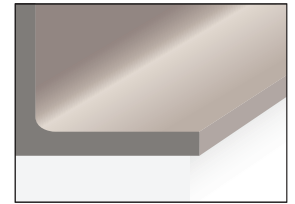

Coved upstand

### ELECTRIC AND INDUCTION COOKTOPS

A minimum 50mm clearance from the back edge of the cooktop is recommended

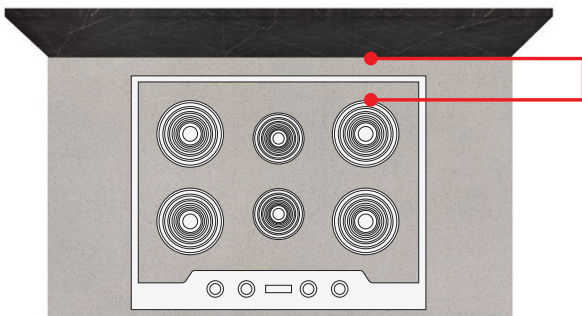

**50mm**  
From outer ring.

### GAS COOKTOPS

A minimum of 200mm clearance from the periphery of the gas burner.

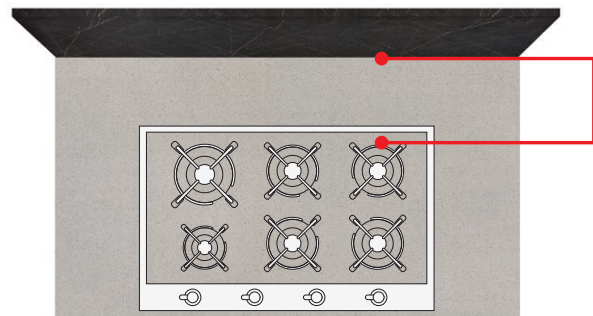

**200mm**  
From gas trivet.

When designing or installing splashbacks, compliance with the Australian and New Zealand standards and guidelines needs to be considered by all parties involved in the design, manufacture and installation of a kitchen.

# Backlighting

The HI-MACS® Acrylic Solid Surface colour range includes 4 colours which have translucent properties – Opal, Ruby, Gemini and Aurora Pavia. The translucent nature of these products allow you to integrate backlit design capabilities and the material can be engraved or include customised inlays.





---

## THE FOLLOWING IMPORTANT DESIGN CONSIDERATIONS SHOULD BE TAKEN INTO ACCOUNT:

---

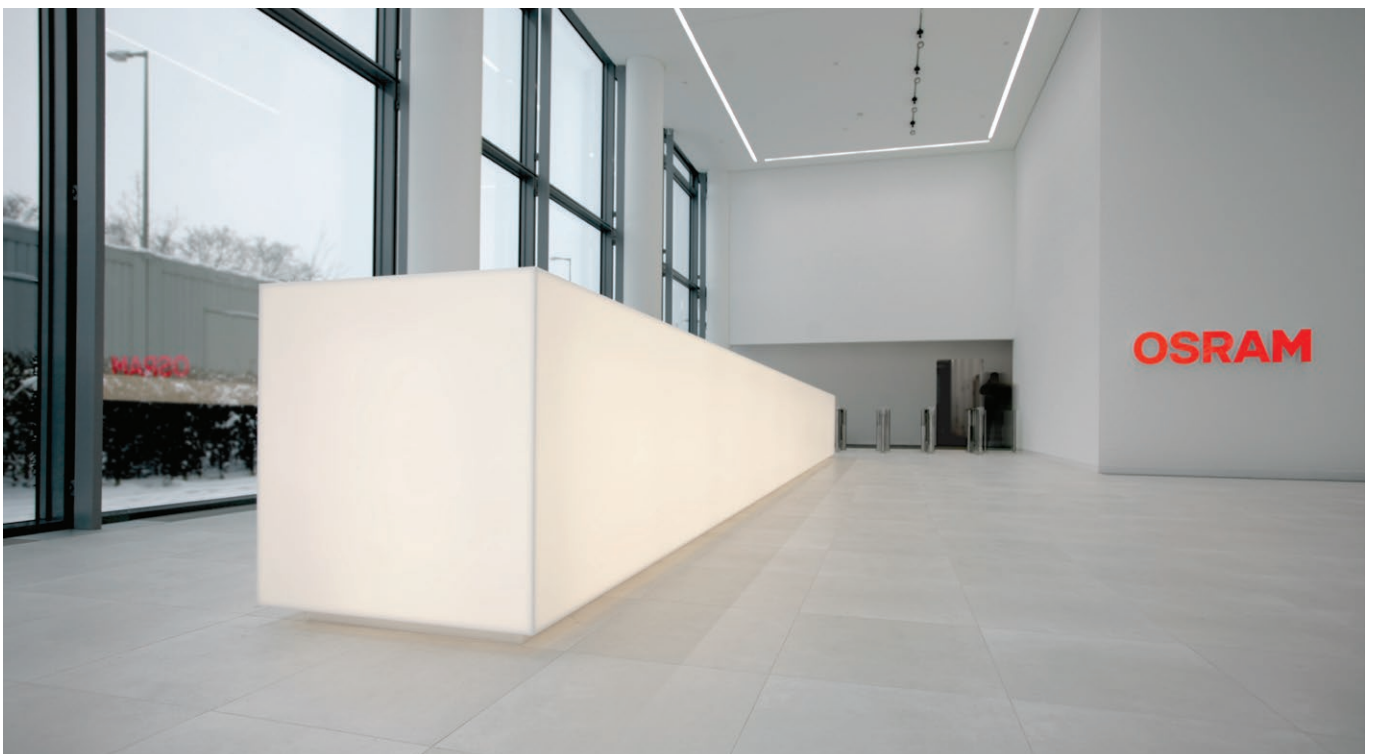
1. Seams (joins between pieces of solid surface material) will be more visible when backlit, due to the different translucent properties of the adhesive. Where possible, seams should be placed where they will be less noticeable, such as in corners, or in shadows.
2. Thermoforming of translucent colours is possible. As some very slight colour changes can occur during thermoforming, it is advisable to test samples beforehand.
3. Supports (such as brackets) and fixings (such as bolts or screws) will be noticeable, and care should be taken to place them where they will be less noticeable.
4. Different types of lighting can be used to create different colours of translucence. Please test the exact type of lighting with a sample of HI-MACS® Acrylic Solid Surface to see final effect.





# Specification Notes

In order to ensure that your HI-MACS® Acrylic Solid Surfaces project is as successful as possible, please see a guide below for notes that should be included in the project specification:

SPECIFY HI-MACS® ACRYLIC SOLID SURFACE **COLOUR**. CONSULT LAMINEX NEW ZEALAND™ FOR AVAILABLE COLOURS.

Colour: \_\_\_\_\_ .

- Solid surfacing to be fabricated of same colour from same production batch

SPECIFY SOLID SURFACING **FINISH**.

Finish:

[Matte] 360 – 500

[Satin] 600 – 800

[Gloss] (not recommended for all applications).

- Uniform finish on exposed surfaces

SPECIFY SOLID SURFACING **EDGE TREATMENT** HERE OR ON THE DRAWINGS.

Edge Treatment: [ \_\_\_\_\_ ]

(as indicated on the drawings).

SPECIFY SOLID SURFACING **JOINS / SEAMS**.

1. Locate and fabricate seams in accordance with Laminex New Zealand™ instructions.
2. Do not locate seams through cooktop cutouts.

SPECIFY **FABRICATION**

Fabrication to be completed by a Laminex Zealand™ approved fabricator

# Performance Reports

## CHARACTERISTIC

HI-MACS® Acrylic Solid Surface products are non-porous materials, NSF 51 Certified for Food Preparation areas, that can be applied in many applications where sanitation is of the utmost importance, such as kitchen benchtops, hospitals, playrooms, schools, and many more.

### CLEANING RECOMMENDATIONS FOR COMMON CHEMICALS

Classification	%	Gritty Cleaner or Water	Scotch Brite™ (or Sandpaper for professional repair)	Classification	%	Gritty Cleaner or Water	Scotch Brite™ (or Sandpaper for professional repair)
Acetic Acid	5	✓		Kerosene	20	✓	
Acetic Acid	10	✓		Methyl Alcohol	5	✓	
Acetic Acid	90		✓	Methyl Ethyl Ketone		✓	
Acetic Acid	98		✓	Mineral Oil		✓	
Acetone		✓		Nitric Acid	10		✓
Aqua Regia			✓	Nitric Acid	30		✓
Ammonia	10	✓		Nitric Acid	40		✓
Ammonium Hydroxide	5	✓		Nitric Acid	70		✓
Ammonium Hydroxide	28	✓		Phenol	40		✓
Benzene		✓		Phenol	85		✓
Calcium Thiocyanate	78	✓		Phosphoric Acid	25		✓
Chloric Hydroxide	20		✓	Phosphoric Acid	85		✓
Chloroform	100		✓	Silver Nitrate	10	✓	
Citric Acid	10	✓		Sodium Hydroxide	10	✓	
Dimethyl Formamide		✓		Sodium Hydroxide	25	✓	
Ethanol	95	✓		Sodium Hydroxide	40	✓	
Ethyl Ether		✓		Sodium Hypochlorite		✓	
Formic Acid	88		✓	Sodium Sulphate		✓	
Formaldehyde		✓		Sulphuric Acid	25	✓	
Furfural			✓	Sulphuric Acid	30	✓	
Gasoline		✓		Sulphuric Acid	77		✓
Hydrochloric Acid	10	✓		Sulphuric Acid	96		✓
Hydrochloric Acid	20	✓		Toluene			✓
Hydrochloric Acid	37	✓		Xylene		✓	
Isopropyl Alcohol		✓		Zinc Chloride		✓	

\*\* This Technical information is designed to provide support in fabrication, installation, and/or to ensure performance of HI-MACS® Acrylic Solid Surface. The information is based on the technical data which Laminex New Zealand™ believe to be reliable and is intended for person or persons having knowledge of this technical area. None of the contents, including but not limited to the instructions, recommendations, graphics, techniques, and guidelines should be understood as implying of legal, warranty, or any type of liability by Laminex New Zealand™ and its affiliates.

# Performance Reports

## TEST METHOD:

- 16 hours of exposure per substance.
- For exposure to chemicals other than as seen above, it is recommended to test on a sample piece of HI-MACS® Acrylic Solid Surface to confirm suitability for application.
- Common domestic residues, such as the examples listed below removed with water and household cleaners.

Alcohol	Hair dyes	Shoe polish
Ink	Juices	Soy sauce
Cigarette stain	Lipsticks	Sugar
Coffee	Lotions	Tea
Cooking oil	Mustard	Tomato sauce
Crayon	Nail polish	Vinegar
Curry powder	Pencil lead	Wine
Make-up	Salt	Food colouring

\*\* This Technical information is designed to provide support in fabrication, installation, and/or to ensure performance of HI-MACS® Acrylic Solid Surface. The information is based on the technical data which Laminex New Zealand™ believe to be reliable and is intended for person or persons having knowledge of this technical area. None of the contents, including but not limited to the instructions, recommendations, graphics, techniques, and guidelines should be understood as implying of legal, warranty, or any type of liability by Laminex New Zealand™ and its affiliates.

## CHEMICAL RESISTANCE

According to DIN 68861 & KIN 68930 Tab. 1

Test material	Assessment	Assessment
G25 defects	S06 defects	
Acetic acid (vinegar)	no effect	no effect
Citric acid (lemon)	no effect	no effect
Natrium carbonate	no effect	no effect
Ammoniac water	no effect	no effect
Ethyl alcohol	no effect	no effect
White/Red wine	no effect	no effect
Beer	no effect	no effect
Cola-drinks	no effect	no effect
Instant coffee	no effect	no effect
Black tea	no effect	no effect
Blackcurrant juice	no effect	no effect
Cream	no effect	no effect
Water	no effect	no effect
Benzine	no effect	no effect
Acetone	3	3
Ethyl-butyl acetate	3	3
Butter	no effect	no effect
Olive oil	no effect	no effect
Mustard	no effect	no effect
Salt	no effect	no effect
Onion	no effect	no effect
Lipstick	no effect	no effect
Disinfectant	no effect	no effect
Black ballpoint	2-3	2-3
Stamping ink	1	1
Household cleaner	no effect	no effect
Cleaning agent	no effect	no effect
Use group according to DIN 68861	1B	1B
Assessment according to DIN 68930 Tab.1		
Other work top spaces: ues group : 1C		
		Fulfill of requirements+

# Frequently Asked Questions

---

## WHAT IS HI-MACS® ACRYLIC SOLID SURFACE?

---

HI-MACS® Acrylic Solid Surface is an acrylic material ideal for residential and commercial applications because of its beauty, durability, aesthetics, design flexibility, colour choices, and more. They can be applied in many applications where sanitation is of utmost importance, such as kitchen benchtops, hospitals, playrooms, schools, and many more.

---

## WHAT IS HI-MACS® ACRYLIC SOLID SURFACE MADE OF?

---

HI-MACS® Acrylic Solid Surface is made with a composition of Methyl Methacrylate (MMA) and Poly Methyl Methacrylate (PMMA) resin filled with Alumina-Trihydrate and other specialized formula to give it the timeless beauty and quality.

---

## IS HI-MACS® ACRYLIC SOLID SURFACE REPAIRABLE?

---

Unlike many other surfacing materials, HI-MACS® Acrylic Solid Surface can be repaired to its original condition by approved HI-MACS® Acrylic Solid Surface fabricators. HI-MACS® Acrylic Solid Surface is non-porous and solid throughout the entire material. These features make HI-MACS® Acrylic Solid Surface completely repairable. Please see the Care & Maintenance section for more details. A small piece from the same batch should be left on-site for any future repairs

---

## HOW DO I CLEAN AND TAKE CARE OF MY HI-MACS® ACRYLIC SOLID SURFACE COUNTERTOP?

---

HI-MACS® Acrylic Solid Surface is non porous and solid through the entire material (6mm or 12mm). The properties of HI-MACS® Acrylic Solid Surface make it a low maintenance surface. To ensure long lasting beauty, follow the guidelines to prevent damages and care for your investment. Please see the Care & Maintenance section for more details.

---

## WHAT IS NSF 51?

---

National Sanitation Foundation 51 > is the standard for "Plastic material and components used in food equipment." According to the NSF website ([www.nsf.org](http://www.nsf.org)), "No other independent testing programs require companies to comply with the strict standards imposed by NSF and its product certification programs. From extensive product testing and material analyses to unannounced plant inspections, NSF is the only third-party testing organization to undertake a complete evaluation of every aspect of a product's development before it can earn our certification."

NSF 51 is one of the Certification program specifically designed for Food Preparation Area. NSF imposes strictest standards to ensure consumer health and safety. HI-MACS® Acrylic Solid Surface have been tested by NSF, Certified, and is currently listed as NSF 51 Certified.

---

## ARE THERE DIFFERENT FINISHES IN HI-MACS® ACRYLIC SOLID SURFACE?

---

Your HI-MACS® Acrylic Solid Surface can be finished to have Matte, Satin and in some cases High-gloss finish. High-gloss finish will scratch more readily and requires care to maintain its original finish. Any scratches can be removed by a fabricator. Remember, some colours may require more maintenance with different finishes. Please consult with your fabricator, or Laminex New Zealand™ representative for the recommendation to best suit your needs.

---

## WHAT ARE THE HEAT-RESISTANCE PROPERTIES OF HI-MACS® ACRYLIC SOLID SURFACE?

---

The innate feature of HI-MACS® Acrylic Solid Surface has heat resistant properties. However, to prevent any damage from direct heat, never place hot items directly on HI-MACS® Acrylic Solid Surface. Always use trivets with rubber feet when placing hot items on the countertop. Remember, placing hot pans or heat-generating appliances directly on HI-MACS® Acrylic Solid Surface may cause damage to your countertop. Avoid direct and indirect heat with temperatures over 80oC (170oF). In most cases, the damage can be repaired, however to protect your HI-MACS® Acrylic Solid Surface countertop, always use a trivet when placing hot items or heat-generating appliances.

---



# Care & Maintenance

HI-MACS® Acrylic Solid Surface is non-porous and solid through the entire material. These features make HI-MACS® Acrylic Solid Surface low maintenance and repairable. To ensure long lasting beauty, follow these guidelines to prevent damages and care for your investment

---

## EVERYDAY CLEANING:

---

- Wipe clean with a damp cloth or sponge
- Basic stains: Clean with mild detergents or general purpose cleaners.
- Periodically go over entire surface with an abrasive cream cleanser (such as Jif) or wet Grey Scotch Brite™ pad to maintain a uniform appearance.

---

## HEAT DAMAGE:

---

- The innate feature of HI-MACS® Acrylic Solid Surface gives it heat resistant properties. However, to prevent any damages from direct heat, never place hot items directly on HI-MACS® Acrylic Solid Surface.
- Always use trivets with rubber feet when placing hot items on the countertop.
- Remember, placing hot pans or heat-generating appliances directly on HI-MACS® Acrylic Solid Surface may cause damage to your countertop. Avoid direct and indirect heat with temperatures over 80oC (170oF)

---

## CHEMICAL DAMAGE:

---

Avoid strong chemicals that can cause damages to your surface such as oven cleaners, acetone, paint removers and others. If exposed, promptly flush with water. Remember, prolonged contact with harsh chemicals can cause serious damage to your benchtop.

---

## SIMPLE STEPS TO AVOID DAMAGE:

---

- Avoid cutting directly on HI-MACS® Acrylic Solid Surface, use a cutting board.
- Never place hot pans directly on the countertop. Even though HI-MACS® Acrylic Solid Surface can withstand high temperatures, prolonged or extreme heat could cause permanent damage.
- Strong acids, such as those found in drain cleaners should be flushed with water immediately. Some of these items, when left on surface may cause whitening, which can be difficult to remove.

---

## REMOVING PERSISTENT STAINS AND MINOR SCRATCHES:

---

- To remove persistent stains, cigarette burns or scratches: scrub with a mild abrasive cleanser and grey Scotch Brite™ pad.
  - Minor scratches can be removed by carefully sanding lightly with 150 grit sandpaper, followed by 240 grit and finishing with 320 grit sandpaper. Complete by rubbing the surface with a wet, grey Scotch Brite™ pad in a circular motion to restore the finish.
  - Note: different methods can be used depending on the finish.
  - Repairs of major damage should only be carried out by approved HI-MACS® Acrylic Solid Surface fabricators. Homeowners should not attempt major repairs.
-